

**MODEL "251CRR-3" CHAIN DRIVEN LIVE ROLLER CONVEYOR - 3" CENTERS
ASSEMBLY AND OPERATING INSTRUCTIONS**

RECEIVING INSTRUCTIONS

- 1) Prior to uncrating the equipment, check the number of crates, boxes, skids, etc. received against the freight bill to insure that all items shipped are on the job site.
- 2) Check to see that none of the equipment was damaged in transit. If damages occurred, note damages on freight bill and immediately contact the motor carrier and file claim for the damages.
- 3) Transport conveyors on their skids as near the installation site as possible.

INSTALLATION INSTRUCTIONS – MECHANICAL

- 1) Remove conveyor sections from their skids and place on floor in proper sequence based on the match mark identification on the conveyor sections and direction of product flow (See Figure "0" for clarification). If fork lift is used make sure forks or fork extensions are long enough to support both side rails of conveyor.

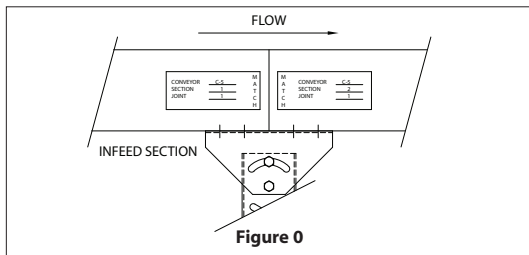

Figure 0

- 2) Beginning with the first section in match mark sequence, bolt a support at each end, leaving a space for the second bed section on pivot plate. Set stands at proper elevation. (See Figure "1" for support positions). Finger tighten bolts only and place into position.
- 3) Take the next intermediate section in the match mark sequence and add one stand to far end, bolting on 1/2 of pivot plate. Finger tighten

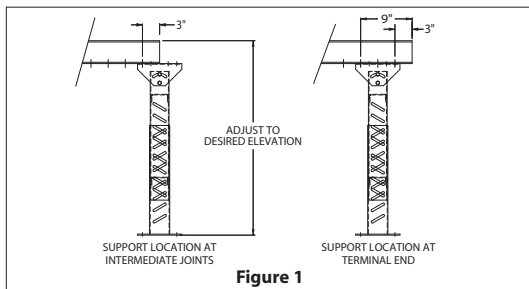

Figure 1

stand bolts, and attach end without stand to previous section. Repeat this procedure until complete conveyor is assembled.

- 4) Do no wrench tighten bolts until unit is assembled, aligned, and lagged to the floor.

- 5) Align Conveyor - To align conveyor, tie a chalk line at each end of the conveyor and pull it tight. Take each section of the conveyor starting at one end and align the frames so that the chalk line is in the exact center of each section of the conveyor.
- 6) Place level across width of conveyor to make sure conveyor is level.
- 7) Install lag bolts (not furnished) through holes in support feet.
- 8) Wrench tighten all bolts and recheck alignment.
- 10) Remove top half of chain guard to expose roller-to-roller chain connections. A loose chain loop with master link has been shipped attached to the last roller in each section. This loop is to connect the last roller in each section with the first roller in the next section. Install all of these loops at this time.

SAFETY INFORMATION

- 1) After completion of conveyor installation and **BEFORE** operation, personnel operating the conveyor must be properly trained in it's use. It is recommended these employees be walked through the proper sequence of starting and stopping the motor drive, shown where hazardous areas exist along the length of the conveyor (identified by safety labels attached to the conveyor frame and drive guards) and correct loading and unloading methods. Make sure that safety labels are legible and that personnel understand their meaning.
- 2) Conveyor should **NEVER** be operated with any of the safety guards removed as physical harm could come to the user. All pinch points of the conveyor are guarded and also identified by safety labels attached in the guarded pinch point area. Instruct users to turn the conveyor off and notify the proper personnel should a guard be missing and the conveyor is running.
- 3) Only qualified maintenance personnel should perform work on the conveyor. Should the unit require maintenance, **disconnect conveyor motor drive from power source before attempting to adjust or repair conveyor**. If guards were removed to perform the maintenance task, they **must be replaced** before attempting to operate conveyor. If guards are damaged and become unusable they must be replaced. Locate the conveyor's serial number plate, which is mounted near the motor drive, and contact your ACSI distributor for a replacement. He will need the serial number of the conveyor to secure the correct guard.

OPERATING INSTRUCTIONS

- 1) Before the electric motor is started, check the following items:
 - A) Make sure correct voltage is connected to motor in accordance with motor name plate.

**- PARTS LIST -
251CRR-3**

- B) The speed reducer is shipped from the factory with oil. However, remove upper most filler plug to insure reducer is oiled properly. If not, fill with oil in accordance with manufacturer's instructions sent with reducer. The reducer may have a loose breather plug attached. If so, you must install breather plug in the reducer in accordance with the installation instructions furnished with the speed reducer to prevent oil seal failure.
- C) Remove chain guard at motor and reducer. Check sprocket alignment with straight edge and proper chain (or driver belt) tension. (See Figure "2" below.)

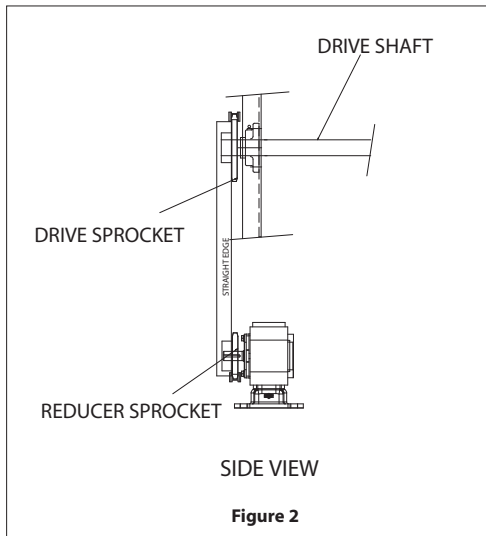

- D) Conveyor can now be started.

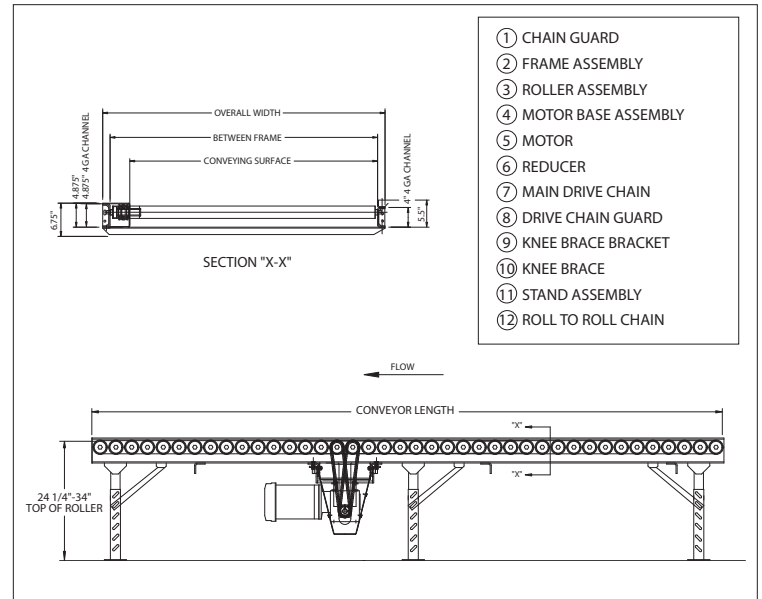

PREVENTATIVE MAINTENANCE

(See Lubrication and Maintenance Check List for more details.)

- 1) **DRIVE CHAINS** - Every 750 hours - Wipe off grease with solvent and apply clean SAE 20 motor oil. Check tension on main drive chain (1/4" - 2% (of sprocket centers) movement midway between sprockets). Use straight edge and check sprocket alignment.
- 2) **ELECTRIC MOTOR** - Every 1000 hours - Remove grease plugs (if supplied on motor) and grease motor bearings sparingly with ball bearing grease.
- 3) **SPEED REDUCER** - Every 750 hours - Remove filler and drain plugs. Flush and refill with lubricant suggested by reducer manufacturer.
- 4) **TREAD ROLLERS** - Every 500 Hours - Make sure all rollers turn freely. Replace any that are dented, warped, binding, etc.
- 5) **ENTIRE CONVEYOR** - Daily, weekly. - Look for any abnormal action of conveyor, oil leaks, unusual noises, etc. Repair at once.