

MODEL "251SR & 251SRC"

Gravity Roller Conveyor

STANDARD SPECIFICATIONS

Frames - 4" x 4 gauge steel channel with bolted cross members, powder painted. Rollers set 1/4" high.

Rollers - 2 1/2" x 11 gauge steel tubing with swaged bearings.

Bearings - Labyrinth sealed and grease packed.

Axles - 1 1/16" hex shaft, spring-loaded.

Couplings - Splice plates, for bolting sections together.

Widths - 13" between frames (B/F) and wider in two inch increments up to 27" between frames. Also 31", 33", 37", 39", 45", 51", 55" and 59" between frames.

Lengths - 10' and 5' straight sections.

Curve Degree - 45° and 90° with 2' 8 1/2" inside radius for widths up to 27" between frames. 4'0" inside radius for 31", 33", 37", and 39" between frames. Tapered roller curve available.

Capacity - 650 pounds per roller with 3,750 pounds maximum distributed live load over 10 feet for 12" nominal roll to 3,500 pounds on widest sizes; 8,000 pounds maximum distributed live load over 5' lengths. Curve sections same as 10'. All capacities based on 3" centers.

CURVED SECTIONS - WEIGHTS

	Nominal Roller Length (Inches)	Width Between Frames (Inches)	Model No. (For 90°)	90° Weight (lbs.)	45° Weight (lbs.)
Single Roller	12	13	251SRC-13-90S	165	84
16 Per 90° Curve	14	15	251SRC-15-90S	180	91
	16	17	251SRC-17-90S	195	99
	18	19	251SRC-19-90S	210	106
	22	23	251SRC-23-90S	240	121
	26	27	251SRC-27-90S	270	136
Double Rollers	30*	31	251SRC-31-90D	400	216
37 Per 90° Curve	32*	33	251SRC-33-90D	418	236
	36*	37	251SRC-37-90D	453	245
	38*	39	251SRC-39-90D	471	255

*4'0" inside radius. All others 2' 8 1/2" inside radius.

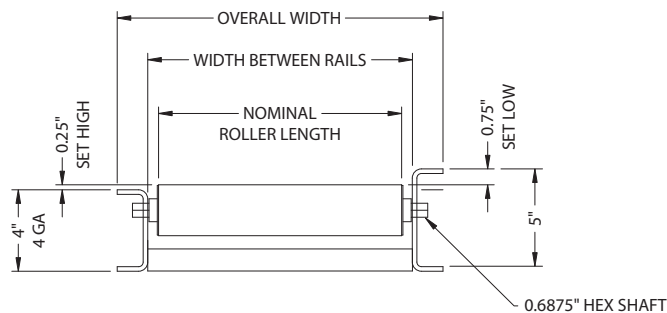

STRAIGHT SECTIONS - WEIGHTS

Nominal Roller Length	Width Between Frames	Model No.	Roller Centers (Inches)	10' Weight (lbs.)	5' Weight (lbs.)
12"	13"	251SR-13-3	3	364	185
		251SR-13-4	4	303	155
		251SR-13-6	6	242	125
		251SR-13-9	9	212	113
		251SR-13-12	12	182	95
14"	15"	251SR-15-3	3	395	202
		251SR-15-4	4	327	168
		251SR-15-6	6	259	134
		251SR-15-9	9	225	120
		251SR-15-12	12	191	100
16"	17"	251SR-17-3	3	427	218
		251SR-17-4	4	351	180
		251SR-17-6	6	276	142
		251SR-17-9	9	238	127
		251SR-17-12	12	200	104
18"	19"	251SR-19-3	3	458	234
		251SR-19-4	4	375	192
		251SR-19-6	6	292	151
		251SR-19-9	9	251	134
		251SR-19-12	12	209	110
22"	23"	251SR-23-3	3	521	266
		251SR-23-4	4	423	217
		251SR-23-6	6	325	168
		251SR-23-9	9	276	149
		251SR-23-12	12	227	120
26"	27"	251SR-27-3	3	583	289
		251SR-27-4	4	471	242
		251SR-27-6	6	358	186
		251SR-27-9	9	302	163
		251SR-27-12	12	246	129
30"	31"	251SR-31-3	3	646	331
		251SR-31-4	4	519	267
		251SR-31-6	6	391	203
		251SR-31-9	9	328	178
		251SR-31-12	12	264	139
32"	33"	251SR-33-3	3	679	347
		251SR-33-4	4	544	280
		251SR-33-6	6	409	213
		251SR-33-9	9	341	185
		251SR-33-12	12	273	145
36"	37"	251SR-37-3	3	740	379
		251SR-37-4	4	590	304
		251SR-37-6	6	441	229
		251SR-37-9	9	366	199
		251SR-37-12	12	291	154
38"	39"	251SR-39-3	3	771	395
		251SR-39-4	4	614	316
		251SR-39-6	6	457	238
		251SR-39-9	9	379	207
		251SR-39-12	12	300	159
44"	45"	251SR-45-3	3	863	443
		251SR-45-4	4	694	352
		251SR-45-6	6	473	291
		251SR-45-9	9	417	229
		251SR-45-12	12	327	173
50"	51"	251SR-51-3	3	955	491
		251SR-51-4	4	754	388
		251SR-51-6	6	489	344
		251SR-51-9	9	455	251
		251SR-51-12	12	354	187
54"	55"	251SR-55-3	3	1016	523
		251SR-55-4	4	800	412
		251SR-55-6	6	521	360
		251SR-55-9	9	480	265
		251SR-55-12	12	372	196
58"	59"	251SR-59-3	3	1077	555
		251SR-59-4	4	846	436
		251SR-59-6	6	553	376
		251SR-59-9	9	505	279
		251SR-59-12	12	309	205