

MODEL "22CRRCTS"

Chain Driven Live Roller Spur



- Wash down operations
- Oily conditions
- Positive drive

STANDARD SPECIFICATIONS

Drive Chain - No. 40 circular roller chain.

Bed - Conveying surface width 14", 16", 18", 24", 28" and 34". 2½" diameter to 1⅞" diameter tapered rollers, 7/16" hex shafts. Mounted in 10 gauge powder painted formed steel channel frame. Rollers are roller to roller driven.

Rollers - Tapered rollers in curve sections; Straight rollers in straight sections.

Chain Guard - Chain guard is mounted above frame to totally enclose drive chain.

Center Drive - Mounted underneath conveyor in center of curve.

Floor Supports - Adjustable 28" to 42" from floor to top of rollers. One support at each end and center leg on outer rail.

Motor - ½ HP 230/460-3-60 TE motor.

Speed Reducer - C-Face heavy duty worm gear.

Roller Speed - 60 FPM.

Capacity - 850 lbs. total distributed live load.

OPTIONAL EQUIPMENT

Guard Rails - Adjustable channel, continuous channel, steel guard rails available.

Floor Supports - Lower or higher are available. Minimum elevation, 18" from floor to top of rollers.

Ceiling Hangers - ½" diameter threaded rods 8 feet long with locking nuts and mounting hardware. Other lengths are available.

Side Mounted Drive - Drive mounted to side of conveyor bed. Minimum elevation 6". Specify which side drive is to be located.

Rollers Set Low - Tread rollers mounted low in 4½" x 10 gauge formed steel channel frame to form ¾" high guard rails.

Motor - Single phase, energy efficient, explosion proof, etc. Other HP are available.

Roller Speed - Constant and variable roller speeds available.

Electrical Controls - Magnetic starters and push button stations; manual motor starters with overload protection, others.

MODEL "22CRRCTS"



Conveying Surface	Width Between Frames	Overall Width	"R"	"A"		"B"		"C"		"D"		Number of Rollers*		Weight (lbs.)	
				45°	30°	45°	30°	45°	30°	45°	30°	45°	30°	45°	30°
14"	17"	20"	32 1/2"	31 1/2"	43"	30"	41 1/2"	43 9/16"	49"	48 9/16"	68 11/16"	6S-7T	9S-9T	275	325
16"	19"	22"		34 1/2"	47"	33"	45 1/2"	44 15/16"	50 11/16"	51 15/16"	75 11/16"	7S-7T	9S-9T	285	335
18"	21"	24"		37"	51"	35 1/2"	49 1/2"	46 3/8"	52 7/16"	55 3/8"	80 11/16"	8S-7T	10S-9T	310	360
24"	27"	30"		45 1/2"	63"	44"	61 1/2"	50 5/8"	57 5/8"	65 5/8"	95 11/16"	9S-7T	11S-9T	355	405
28"	31"	34"	48"	51"	71"	49 1/2"	69 1/2"	64 3/8"	68 1/2"	77"	113 3/8"	10S-10T	12S-14T	380	430
34"	37"	40"		59 1/2"	83"	58"	81 1/2"	68 5/8"	73 3/4"	87 1/4"	128 3/8"	11S-10T	13S-14T	415	465

* S = Straight Roller T = Tapered Roller

MODEL "22CRRCTS" - 45° CURVE SPUR

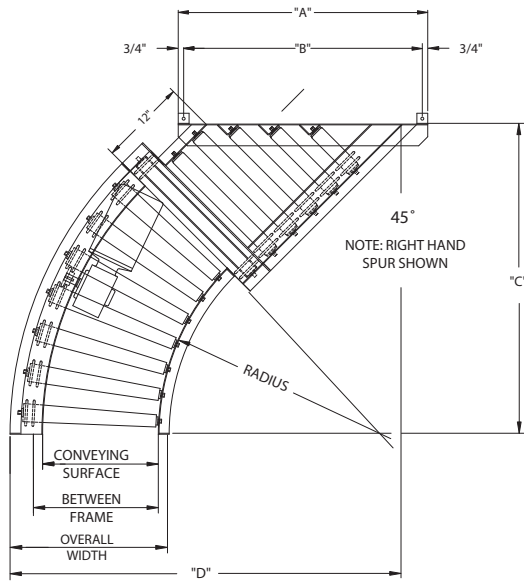

MODEL "22CRRCTS" - 30° CURVE SPUR

