

**MODEL "190LS" LINE SHAFT  
ASSEMBLY AND OPERATING INSTRUCTIONS**

**RECEIVING INSTRUCTIONS**

- 1) Prior to uncrating the equipment, check the number of crates, boxes, skids, etc. received against the freight bill to insure that all items shipped are on the job site.
- 2) Check to see that none of the equipment was damaged in transit. If damages occurred, note damages on freight bill and immediately contact the motor carrier and file claim for the damages.
- 3) Transport conveyors on their skids as near the installation site as possible.

**INSTALLATION INSTRUCTIONS**

- 1) Remove conveyor sections from their skids and place upside down on floor in proper sequence based on the match mark identification on the conveyor sections and direction of product flow. (See figure "0" for clarification).

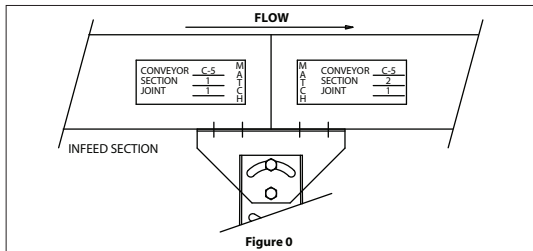

- 2) Beginning with the first section in match mark sequence, bolt a support at each end, leaving a space for the second bed section on pivot plate. Remember to set stands at proper elevation while section is inverted. (See figure "1" for support positions). Finger tighten bolts only and turn section over (right side up) and place into position.
- 3) Take the next intermediate section in the match mark sequence and add one stand to far end, bolting on 1/2 of pivot plate. Finger tighten stand bolts, turn right side up and attach end without stand to previous section. Repeat this procedure until complete conveyor is assembled.

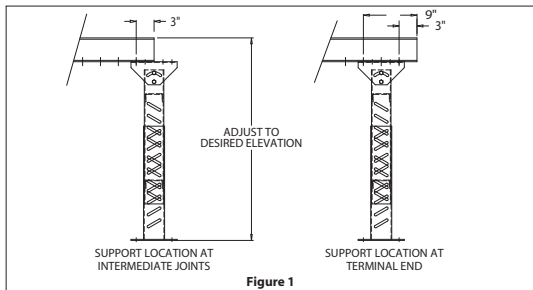

- 4) Do not wrench tighten bolts until unit is assembled, aligned, and lagged to the floor.
- 5) Align Conveyor - To align conveyor, tie a chalk line to the exact center of the rollers at each end of the conveyor and pull it tight. Take each section of the conveyor starting at one end and align the frames so that the chalk line is in the exact center

of each section of the conveyor.

- 6) Place level across width of conveyor to make sure conveyor is level.
- 7) Install lag bolts (not furnished) through holes in support feet.
- 8) Recheck alignment and wrench tighten all bolts.
- 9) Recheck alignment.
- 10) Remove shipping plates from groove rollers before starting unit.

**INSTALLATION OF DELRIN COUPLINGS**

- 1) Each bed joint is equipped with a Delrin chain coupling. The line shaft bearings and chain couplings are fixture assembled at the factory with proper clearance and alignment prior to shipment. However, it can become misaligned in transit and should be checked thoroughly prior to use.
- 2) Remove the end two tread rollers of each mating section of conveyor to expose the two metal sprockets (coupling halves) of the chain coupling.
- 3) Check the coupling halves to insure a gap of 9/32" between sprockets exists. This can be checked with a piece of 1/4" thick cold rolled flat bar and a feeler gauge set at 1/32". (See figure "2")
- 4) Angular Alignment: Coupling will tolerate a maximum of 1 degree angular misalignment, but for optimum life, a maximum of 1/2 degree is recommended. Angular alignment is checked by keeping both shafts stationary and taking measurements with a feeler gauge at the four points - A, B, C, D, (Figure "2"). The difference between A and C will give the error in alignment in the vertical plane. Likewise the difference between B and D gives the error in alignment in the horizontal plane.

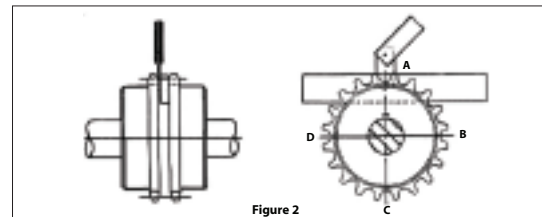

- 5) Parallel Alignment: Can be checked with a straight edge placed on the two sprockets as shown in figure "3". Alignment should be checked in at least two places - at 90 degree intervals.

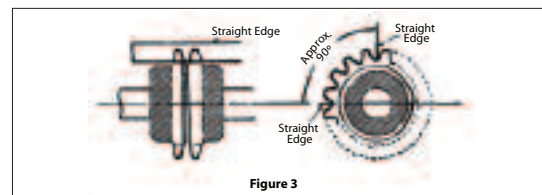

- 6) Lag conveyor to floor, if floor mounted. Wrench tighten all bolts. Re-check coupling alignment before running conveyor. If couplings are misaligned, re-check 3 through 5 above.
- 7) When the shafts are properly aligned, the chain will easily wrap the sprockets for final coupling assembly. If the chain does not go on easily, recheck 3C, 3D and 3E above. Caution must be exercised when installing the press fit groove pin to insure that the Delrin link is not damaged. Support link immediately adjacent to the pin by means of a "C" clamp, vise grip pliers or other similar devices as shown in figure "4".

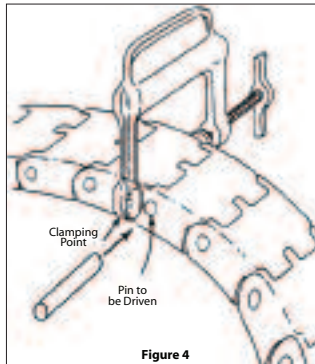

- 8) Conveyor is now ready for start up. (See "Safety Information" & "Operating Instructions.")
- 9) Disassembly of the press fit groove pin can be accomplished by supporting the link immediately adjacent to the pin (see figure "4" above) and driving pin out with the proper drift pin.

### SAFETY INFORMATION

- 1) After completion of conveyor installation and **BEFORE** operation, personnel operating the conveyor must be properly trained in its use. It is recommended these employees be walked through the proper sequence of starting and stopping the motor drive, shown where hazardous areas exist along the length of the conveyor (identified by safety labels attached to the conveyor frame and drive guards) and correct loading and unloading methods. Make sure safety labels are legible and that personnel understand their meaning.
- 2) Conveyor should **NEVER** be operated with any of the safety guards removed as physical harm could come to the user. All pinch points of the conveyor are guarded and also identified by safety labels attached in the guarded pinch point area. Instruct users to turn the conveyor off and notify the proper personnel should a guard be missing and the conveyor is running.
- 3) Only qualified maintenance personnel should perform work on the conveyor. Should the unit require maintenance, **disconnect conveyor motor drive from power source before attempting to adjust or repair conveyor.** If guards were removed to perform the maintenance task, they must be replaced before attempting to operate conveyor. If guards are damaged and become unusable they must be replaced. Locate the conveyor's serial number plate, which is mounted near

the motor drive, and contact your ACSI distributor for a replacement. He will need the serial number of the conveyor to secure the correct guard.

### OPERATING INSTRUCTIONS

- 1) Before the electric motor is turned on, check the following items:
  - A) Make sure correct voltage is connected to motor in accordance with motor name plate.
  - B) The speed reducer is shipped from the factory with oil. However, remove upper most filler plug to insure reducer is oiled properly. If not, fill with oil in accordance with manufacturer's instructions sent with reducer. The reducer may have a loose breather plug attached. If so, you must install breather plug in the reducer in accordance with the installation instructions furnished with the speed reducer to prevent oil seal failure.
  - C) Remove chain guard at motor and reducer. Check sprocket alignment with straight edge and proper chain (or driver belt) tension. (See figures below.)

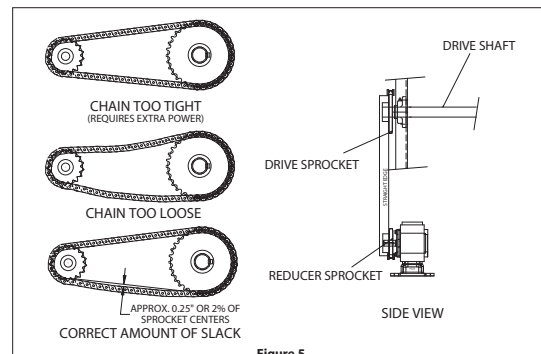

- D) Conveyor is now ready to operate.

### PREVENTATIVE MAINTENANCE

(See Lubrication and Maintenance Check List for more details.)

- 1) **DRIVE CHAINS** - Every 750 hours - Wipe off grease with solvent and apply clean SAE 20 motor oil. Check tension on main drive chain (1/4" - 2% (of sprocket centers) movement midway between sprockets). Use straight edge and check sprocket alignment.
- 2) **ELECTRIC MOTOR** - Every 1000 hours - Remove grease plugs (if supplied on motor) and grease motor bearings sparingly with ball bearing grease.
- 3) **SPEED REDUCER** - Every 750 hours - Remove filler and drain plugs. Flush and refill with lubricant suggested by reducer manufacturer.
- 4) **TREAD ROLLERS** - Every 500 Hours - Make sure all rollers turn freely. Replace any that are dented, warped, binding, etc.
- 5) **FLANGE MOUNTED BEARINGS (PULLEYS)** - Every 1000 hours - Grease pulley bearings through grease fittings using grease gun. CAUTION: Do not over grease.
- 6) **ENTIRE CONVEYOR** - Daily, weekly. - Look for any abnormal action of conveyor, oil leaks, unusual noises, etc. Repair at once.



